



OPERATING MANUAL

This manual MUST be kept and stored with the aerial platform at all times.



SJ-600, 800 & 1000 Series Engine Powered

For Service please call **800 275-9522**
 Skyjack Inc. Service Center, 3451 Swenson Ave., St. Charles, IL. 60174 ... *FAX 630 262-0006*
 For Parts in North America and Asia please call **800 965-4626**
 Skyjack Inc. Parts Center, 3451 Swenson Ave., St. Charles, IL. 60174 *FAX 888 782-4825*
 For Parts & Service in Europe please call **31 297 255 526**
 Skyjack Europe Communicatieweg 29, 3641 SG Mijdrecht Netherlands *FAX 31 297 256 948*



WARNING

This Operating Manual and the “ANSI/SIA Manual Of Responsibilities” are considered fundamental parts of the elevating work platform. They are a very important way to communicate necessary safety information to users and operators. A complete and legible copy of these manuals **MUST BE KEPT ON THE WORK PLATFORM** in the provided weather resistant storage compartment at all times.

California Proposition 65

WARNING:

Some Materials and Fuels Used On This Equipment Are Known To The State Of California To Cause Cancer, Birth Defects and Other Reproductive Harm.

Engine Exhaust and Some Of Its Constituents Are Known To The State Of California To Cause Cancer, Birth Defects, and Other Reproductive Harm.

USE THE SERIAL NUMBER OF YOUR MACHINE TO DETERMINE THE CORRECT Operating Manual TO USE							
MANUAL PART NUMBER		118945AA	122883AH	129907AB	129921AC (CE)	129922AC (ANSI/CSA)	
Release Date		January 2000	June 2002	August 2003	May 2005	May 2005	
M O D E L S	Mid Size RTs	7027	33188 & Below	33189 & Above	Not Used		
		7127 7135 8243 8850	Not Used	340000 to 340268	340269 to 341123	341124 & Above	
	Full Size RTs	8831	37054 & Below	37055 to 37361	37362 to 37451	37452 & Above	
		8841	42202 & Below	42203 to 42837	42838 to 43103	43104 & Above	
		9250	50771 & Below	50772 to 51094	51095 to 51388	51389 & Above	

60101AH

Table Of Contents

<u>Section - Paragraph</u>	<u>Page No.</u>
Section 1 - Introduction	
Purpose Of Equipment	7
Use Of Equipment	7
Warnings	7
Description	7
Operator Warnings	8
Specifications And Features	9
Standard Features And Optional Equipment	10
Work Platform Major Component Identification	11
Section 2 - Operation	
Operating Control Identification	
Base Controls	
Electrical Panel	13
Emergency Battery Disconnect	13
Engine Control Panel	14
Base Control Box/Station	15
Emergency Powered Extension Platform	15
1500W AC Inverter	15
Platform Controls	
Operator's Control Box	16
Outrigger Controls	17
Hydraulic Generator Control	17
Powered Extension Platform Control Box	17
Identification And Operation Of Safety Devices	18
Operating Procedures	
Set-up Procedure	19
Prestart Checks	20
Operator Qualifications	21
Start and Operation	21
Shutdown Procedure	22
Emergency Lowering System	23
Outrigger Operating Procedures	24
Hydraulic Generator (Option)	24
Electrical Inverter (Option)	24
Winching And Towing Procedures	25
Owners Annual Inspection Record	27
Maximum Platform Capacities	27, 28
Maintenance And Inspection Schedule	29

List Of Tables

TABLE 1-1. Specifications And Features	Section 1	Page 9
TABLE 1-1. Standard Features And Optional Equipment	Section 1	Page 10
TABLE 2-1. Owners Annual Inspection Record	Section 2	Page 27
TABLE 2-2. Tire Specifications	Section 2	Page 28
TABLE 2-3. Maximum Platform Capacities	Section 2	Page 29
TABLE 2-4. Maintenance And Inspection Schedule	Section 2	Page 30

 **WARNING**

ANSI/SIA (United States)

You are required by the current ANSI/SIA A92.6 standards to read and understand YOUR RESPONSIBILITIES in the Manual Of Responsibilities before you use or operate this work platform.

CSA (Canada) and CE (Europe)

You are required to conform to national health and safety regulations applicable to the operation of this elevating work platform.

FAILURE TO COMPLY with your REQUIRED RESPONSIBILITIES in the use and operation of the work platform could result in DEATH OR SERIOUS INJURY!

OPERATOR SAFETY REMINDERS

The National Safety Council reminds us that most accidents are caused by the failure of some individuals to follow simple and fundamental safety rules and precautions. Common sense dictates the use of protective clothing when working on or near machinery. Use appropriate safety devices to protect your eyes, ears, hands, feet and body.

You, as a careful operator, are the best insurance against an accident. Therefore, proper usage of this work platform is mandatory. The following pages of this manual should be read and understood completely before operating the work platform. Any modifications from the original design are strictly forbidden without written permission from SKYJACK, Inc.

 **DANGER**

ELECTROCUTION HAZARD

THIS MACHINE IS NOT INSULATED. MAINTAIN SAFE CLEARANCES FROM ELECTRICAL POWER LINES AND APPARATUS. YOU MUST ALLOW FOR PLATFORM SWAY, ROCK OR SAG. THIS WORK PLATFORM DOES NOT PROVIDE PROTECTION FROM CONTACT WITH OR PROXIMITY TO AN ELECTRICALLY CHARGED CONDUCTOR.

Minimum Safe Approach Distance

ANSI/SIA A92.6-1999 & CSA CAN3-B354.2&.3-M82 Requirements			CE Guidance Note
Voltage Range (Phase to Phase)	Minimum Safe Approach Distance		"Avoidance of danger from Overhead Lines" These machines should not operate within 15M of overhead lines suspended from steel towers. These machines should not operate within 9M of overhead lines suspended from wooden poles.
	Feet	Meters	
0 To 300V	Avoid Contact		
Over 300V to 50KV	10	3.05	
Over 50KV to 200KV	15	4.60	
Over 200KV to 350KV	20	6.10	
Over 350KV to 500KV	25	7.62	
Over 500KV to 750KV	35	10.67	
Over 750KV to 1000KV	45	13.72	

FAILURE TO AVOID THIS HAZARD WILL RESULT IN DEATH OR SERIOUS INJURY!

DO NOT OPERATE THIS EQUIPMENT WITHOUT PROPER AUTHORIZATION AND TRAINING. DEATH OR SERIOUS INJURY COULD RESULT FROM IMPROPER USE OF THIS EQUIPMENT!

SERVICE POLICY AND WARRANTY

SKYJACK, Inc. warrants each new work platform to be free of defective parts and workmanship during the first 12 months. Refer to [Warranty Statement](#) on Page 6 for details.

NOTE

SKYJACK, Inc. is continuously improving and expanding product features on it's equipment: therefore, specifications and dimensions are subject to change without notice.



This Safety Alert Symbol Means Attention!

Become Alert! Your Safety Is Involved.

The Safety Alert Symbol identifies important safety messages on machines, safety signs, in manuals, or elsewhere. When you see this symbol, be alert to the possibility of personal injury or death. Follow the instructions in the safety message.

SCOPE OF THIS MANUAL

This manual applies to the ANSI/SIA, CSA and CE versions of the SJ-600, SJ-800 and SJ-1000 Series work platform models listed in [Table 1-1](#). Equipment identified with "ANSI/SIA" meets the ANSI/SIA-A92.6-1999 standards. Equipment identified with "CSA" meets the CAN3-B354.2 & .3-M82 standards. Equipment identified with "CE" meets the requirements for the European countries, i.e. Machinery Directive 89/392/EEC and EMC Directive 89/336/EEC and the corresponding EN standards.

WARRANTY STATEMENT

SKYJACK, Inc. warrants each new work platform to be free of defective parts and workmanship. During the first full year, labor and replacement parts will be provided by the local authorized Skyjack dealer without charge. For the following 48 months, structural components found to be defective will be replaced or repaired at no charge.

A warranty registration card is supplied with each work platform. The warranty is only effective when the warranty card has been completed and returned to Skyjack within 15 days from the time of billing. When work platforms are put into stock, the warranty period does not start until the work platform has been shipped to the dealers customer. If a unit is put into service and no warranty card has been mailed to Skyjack, Inc., the warranty period will commence 15 days from the date the dealer was invoiced for the work platform.

All warranty claims are subject to approval by Skyjack's Service Department. Skyjack, Inc. reserves the right to limit or adjust claims with regard to defective parts, labor or travel time based on usual and customary guidelines. Parts purchased from sources other than Skyjack will not be covered under this warranty. Misuse or improper operation, lack of normal maintenance and inspections as outlined in this Operating/Maintenance and Parts Manual, alterations to original design and/or components or accidents will void all warranty. **Batteries are not covered by this warranty.**

The above mentioned warranty statement is exclusive and no other warranty whether written, oral or implied shall apply. Skyjack excludes any implied warranty of merchantability and fitness and accepts no liability for consequential damages or for other negligence.

WARRANTY PROCEDURES

The selling distributor or authorized dealer shall be responsible for the complete handling of customer claims under this warranty. Here's what to do:

1. When a customer files a claim under this warranty, contact Skyjack's Service Department to verify warranty coverage. **NOTE:** The complete serial number of the work platform is required to verify the claim.

2. When Skyjack's Service Department verifies warranty coverage, they will also issue an RA (Return Authorization) number for the return of any defective component(s). All items over \$25.00 in value must be returned to Skyjack, Inc.

3. Fill out a Warranty Claim Form from dealer's supply of claim forms. Then notify Skyjack's Service Department of the warranty claim number on the form used.

4. The distributor/dealer should then file a warranty claim with Skyjack, Inc. describing the nature of the defect, probable cause, work performed, travel hours, and labor hours listed separately. Warranty labor will be paid at a rate of \$42.00 per hour. The travel allowance will be paid at the same hourly rate within the dealers specified territory, limited to a maximum of four (4) hours. If a part has serviceable components, PLEASE replace the bad component. For instance, if you have a bad switch on a controller, please replace the switch. Hydraulic cylinders should be resealed, unless they are damaged beyond repair. Engine failures should be directed to your local engine distributor and covered by the manufacturers warranty. Skyjack will accommodate you and your labor. Labor rates and travel allowances are subject to change without notice.

5. Warranty claims must be received by Skyjack within 15 working days from the date of the repair. Warranty claims received with insufficient information will be returned for correction or completion.

6. Materials returned for warranty inspection must have the following procedures:

A. Carefully packaged to prevent additional damage during shipping.

B. Drained of all contents and all open ports capped or plugged.

C. Shipped in a container tagged or marked with the RA number.

D. Shipped **PREPAID**. Any item(s) returned for warranty by any other means may be refused and returned unless prior approval from Skyjack is obtained.

E. Items shipped to the dealer will be sent freight prepaid and added to the invoice.

Failure to comply with the above procedures may delay approval and processing of the warranty claim and could result in the denial of a warranty claim. Skyjack's dealer's accounts must be kept current in order to approve and issue warranty credits. Skyjack reserves the right to withhold issuance of warranty credits to a dealer if their account is not in good standing. This is subject to change without prior notice.

SECTION 1

INTRODUCTION

Purpose Of Equipment

The SKYJACK SJ-600, 800 & 1000 Series Work Platform is designed to transport and raise personnel, tools and materials to overhead work areas.

Use Of Equipment

The work platform (Figure 1-1) is a highly maneuverable, mobile work station. Lifting and elevated driving MUST be on a flat, level, compacted surface. The work platform can be driven over uneven terrain only when the platform is fully lowered.

Warnings

The operator MUST read and completely understand the safety panel labels and ALL other warnings in this manual and on the work platform. Compare the labels on the work platform with the labels found throughout this manual. If any labels are damaged or missing, replace them immediately.

Description

The work platform consists of three major assemblies, the platform, lifting mechanism and the base. An operator's control box is mounted on the platform railing. Auxiliary and emergency controls are located at the base.

Platform - The platform is constructed of a tubular support frame, a skid-resistant "diamond plate" deck surface, and 43-1/2" (1.10m) hinged railings with 6" (15.24cm) toe boards and mid-rails. The platform can be entered from either side through a spring returned gate for 800 & 1000 Series and from the rear through a spring returned gate on 600 Series. The 600 Series can be equipped with a front extension platform. The 800 & 1000 Series can be equipped with a front or both front and rear extension platforms.

Lifting Mechanism - The lifting mechanism is constructed of formed steel sections making up a scissor-type assembly. The scissor-type assembly is raised and lowered by single-acting hydraulic lift cylinders with holding valves. A two-section pump, driven by an engine provides hydraulic power to the lift cylinders. A safety bar located inside the lifting mechanism (when properly positioned) prevents the scissor-type assembly from being lowered while maintenance or repairs are being performed within the lifting mechanism.

Base - (600 & 800 Series) The base is a rigid one piece weldment which supports two component side cabinets. One cabinet contains the hydraulic components, up/down controls, electrical components and starter battery. The other cabinet contains the fuel tank, hydraulic tank and LP tank (SJ 800). The propane tank on the SJ 600 series is located either behind the access ladder or behind the fuel cabinet. The front axle has two wheels, steerable by a hydraulic cylinder and is either non-driven (2WD models) or drive shaft/gear box driven (4WD models). The rear axle is drive shaft/gear box driven and has a spring-applied hydraulically-released disc parking brake. A slide-out drawer at the front of the base, supports an engine coupled with a two-section hydraulic pump providing power to the hydraulic system. An engine control panel is also located at the front of the base.

Base - (1000 Series) The base is a rigid one piece weldment which supports two component side cabinets. One cabinet contains the hydraulic tank, hydraulic components, up/down controls, electrical components, emergency lowering battery and starter battery. The other cabinet contains the fuel tank and LP tank (if equipped). The front axle has two wheels, steerable by a hydraulic cylinder and is either non-driven (2WD models) or drive shaft/gear box driven (4WD models). The rear axle is drive shaft/gear box driven and has two spring-applied hydraulically-released parking brakes. A slide-out drawer at the front of the base supports an engine coupled with a two-section hydraulic pump providing power to the hydraulic system. An engine control panel is also located at the front of the base.

Operator's Control Box - A removable control box, mounted at the right front of the platform, contains controls for engine operation, work platform motion and emergency stopping.

Hydraulic Outriggers - Optional hydraulic outriggers are mounted to the four corners of the base. Controls on the operator's control box are used to extend and retract the hydraulic outrigger cylinders.

Serial Number Nameplate - The serial number nameplate, located on the rear of the machine, lists the model number, serial number, machine weight, drive height, capacities, platform height, voltage, system and lift pressures, and date manufactured. Use this information for proper operation and maintenance and when ordering service parts.

Optional Accessories - The SKYJACK Work Platform is designed to accept a variety of optional accessories. These are listed in [Table 1-2](#). Standard Features and Optional Equipment. Operating instructions for these options (if required) are located in Section 2 of this manual.

Operator Warnings

Warning

- DO NOT** exert excessive side forces on platform while elevated.
- DO NOT** overload. The lift relief valve does not protect against overloading when the platform is elevated.
- DO NOT** alter or disable limit switches or other safety devices.
- DO NOT** exceed the rated capacity of your scissorlift and make sure the load is evenly distributed on the platform.
- DO NOT** raise your platform in windy or gusty conditions.

Warning

Jobsite Hazards

- DO NOT** operate on surfaces not capable of holding weight of the work platform including the rated load, e.g. covers, drains, and trenches.
- DO NOT** elevate the work platform if it is not on firm level surfaces. Avoid pot holes, loading docks, debris, drop offs and surfaces that may affect the stability of your work platform.

DO NOT climb or descend a grade steeper than 25% (SJ 1000), 30% (SJ 800) or 35% (SJ 600) Elevated driving must only be done on firm level surfaces. (Ref. [Table 1-1](#))

BE AWARE of overhead obstacles, and poorly lit areas in case of overhead obstacles.

ENSURE that there is no person(s) in the path of travel.



Warning

Work Platform Conditions

An Operator Should Not Use Any Work Platform That:

- Has ladders, scaffolding or other devices mounted on it to increase its size or work height.
- Does not have a clean, uncluttered work area.
- Does not appear to be working properly.
- Has been damaged or appears to have worn or missing parts.
- Has alterations or modifications not approved by the manufacturer.
- Has safety devices which have been altered or disabled.

Table 1-1 Specifications And Features

Family		600 Series			800 Series		1000 Series
Model		7027	7127	7135	8831	8841	9250/9250A
Weight*		8,600 lbs. (3450kg)	7,920 lbs. (3593kg)	9,550 lbs. (4332kg)	9,757 lbs. (4426kg)	11,410 lbs.† (5176kg)	14,200 lbs. (6441kg)
Width		70" (1.78 m)	71.5" (1.82m)		87" (2.21m)		92" (2.34m)
Length		119" (3.02 m)	150"†† (3.81m)		137.5" (3.5m)		176" (4.47m)
Platform Size		65" x 112.5" (1.65 x 86m)	64" x 117" (1.63 x 2.97m)		68" x 133.5" (1.73 x 3.39m)		74" x 168" (1.88 x 4.27m)
Height	Working	33' (10.1m)		41' (12.5m)	37' (11.28m)	47' (14.3m)	56' (17.1m)
	Platform Elevated	27' (8.23m)		35' (10.7m)	31' (9.45m)	41' (12.5m)	50' (15.2m)
	Platform Lowered	60" (1.52m)	60.5" (1.54m)	68" (1.73m)	59" (1.50m)	69" (1.75m)	123" (3.12m)
	Drive	Full			Full**		26'*** (7.92m)
Tires		Please Refer to Table 2-2. for tire specification and usage.					
Speed	Normal Drive	3.0 mph (4.8km/h)			3.5 mph (5.6km/h)		2.0 mph (3.2km/h)
	Elevated Low Drive	.6 mph (0.97km/h)	.35 mph (0.56km/h)		.6 mph (0.97km/h)		
	Raise (Rated Load)	39 sec.	40 sec.	40 sec.	80 sec.	90 sec.	67 sec.
	Lower (Rated Load)	33 sec.	40 sec.	40 sec.	53 sec.	44 sec.	72 sec.
Engine (RPM)	Ford Gasoline	Not Applicable			1300 (Low) / 2800 (High)		
	Kubota Diesel	1300 (Low) 2800 (High)	1600 (Low) 2800 (High)		1300 (Low) / 2800 (High)		
	Kubota Gasoline	1500 (Low) 3900 (High)	2050 (Low) 3600 (High)		Not Applicable		
Gradability		35%			30%		25%

- * Weights are approximate, refer to serial nameplate for specific weight. Values shown are for standard 2WD machines with a manual extension platform (SJ 600) and no extension platforms (SJ 800 and SJ1000).
- ** ANSI Only, CE drivable until 26.0' (7.92 m)
- *** Model 9250 Only, model 9250A is drivable at full height (50'(15.2m))
- † Weight is approximate. Refer to serial nameplate for CSA or CE models.
- †† Tires mark fore/aft extremity of machine.

CE Kubota Diesel Models	
Sound Pressure & Power Levels	
NET INSTALLED POWER:	17.1kW
SOUND PRESSURE @ OPERATOR STATION:	79 dB
GUARANTEED SOUND POWER LEVEL:	103 dB



Table 1-2. Standard Features and Optional Equipment

Standard Features (ANSI & CE)

- Operator Horn
- Joystick Control
- Dual Range (torque/speed) Selector
- Movement Alarm (ANSI)
- Diamond Pattern, All Steel Platform Deck Construction
- Hinged Railing System With 6" (15.24cm) Toe Boards
- Access Ladders and Gates at Both Sides of Platform (800 & 1000 Series only)
- AC Outlet on Platform
- D-Rings (Lanyard Attachment Points)
- Self-Centering Scissors Design (800 & 1000 Series only)
- Flashing Light and Descent Alarm
- Scissor Guards (CE Only)
- Lockable Cabinets With Swing-Out Door
- Color-Coded, Numbered Wiring System
- Hourmeter
- Tilt Alarm with Lift/Drive Cut Out
- Base Key Switch Box (CE only)
- Engine Mounted on Slide-Out Tray
- 35 Hp Ford Water-Cooled Gasoline Engine (800 & 1000 Series only) (ANSI)
- 23 Hp Kubota Dual Fuel- Gasoline/Propane (600 Series only) (ANSI)
- Dual Fuel - Gasoline/Propane (ANSI)
- 25 Hp Kubota Diesel Water-Cooled Engine (CE only)
- Tie Down Points
- Independently Operated Hydraulic Outriggers (Model 9250)
- Type #6 Air Filled Tires (Models 9250, 8831, 8841 & 7027)
- Type #6F Foam Filled Tires (Model 9250A, 8831F & 8841F)
- Disc Brake System on Rear Axle (800 & 600 Series only)
- Dual Spring-Applied Hydraulically-Released Parking Brakes (1000 Series only)

Optional Equipment (ANSI & CE)

- Front Mounted 5 Ft. (1.5m) Slide Out Extension Platform (600 Series)
- Front Mounted 5 Ft. (1.5m) Powered Extension Platform (600 Series)
- Front and (or) Rear Mounted 4 Ft. (1.2m) Slide Out Extension Platform (800 Series only)
- Front and (or) Rear Mounted 4 Ft. (1.2m) Powered Extension Platform (800 Series only)
- Front and (or) Rear Mounted 5 Ft. (1.5m) Powered Extension Platform (Model 9250)
- Movement Alarm (CE)
- Rotating Amber Beacon
- Kubota Diesel Water-Cooled Engine (ANSI only)
- 35 Hp Ford Water-Cooled Gasoline Engine (Model 7135 only) (ANSI)
- 4-Wheel Drive Package
- Type #6F Foam Filled Tires (Models 9250, 8831F, 8841F & 7027)
- Type #7F Foam Filled Tires (Models 9250, 7027 & 800 Series)
- Type #8F Foam Filled Tires (600 Series only)
- Type #7 Air Filled Tires (All models except 9250A)
- Type #8 Air Filled Tires (600 & 800 Series)
- Independently Operated Hydraulic Outriggers (Models 7135, 9250A and 800 Series)
- Scissor Guards (ANSI Only)
- 3500 Watt Hydraulic AC Generator
- 1500W AC Inverter

Work Platform Major Component Identification

OPERATOR'S
CONTROL BOX

MAIN
PLATFORM

ENTRY
GATE

LIFTING
MECHANISM

HYDRAULIC TANK
AND FUEL TANK
SIDE CABINET

ENGINE
TRAY

HYDRAULIC/
ELECTRIC
SIDE
CABINET

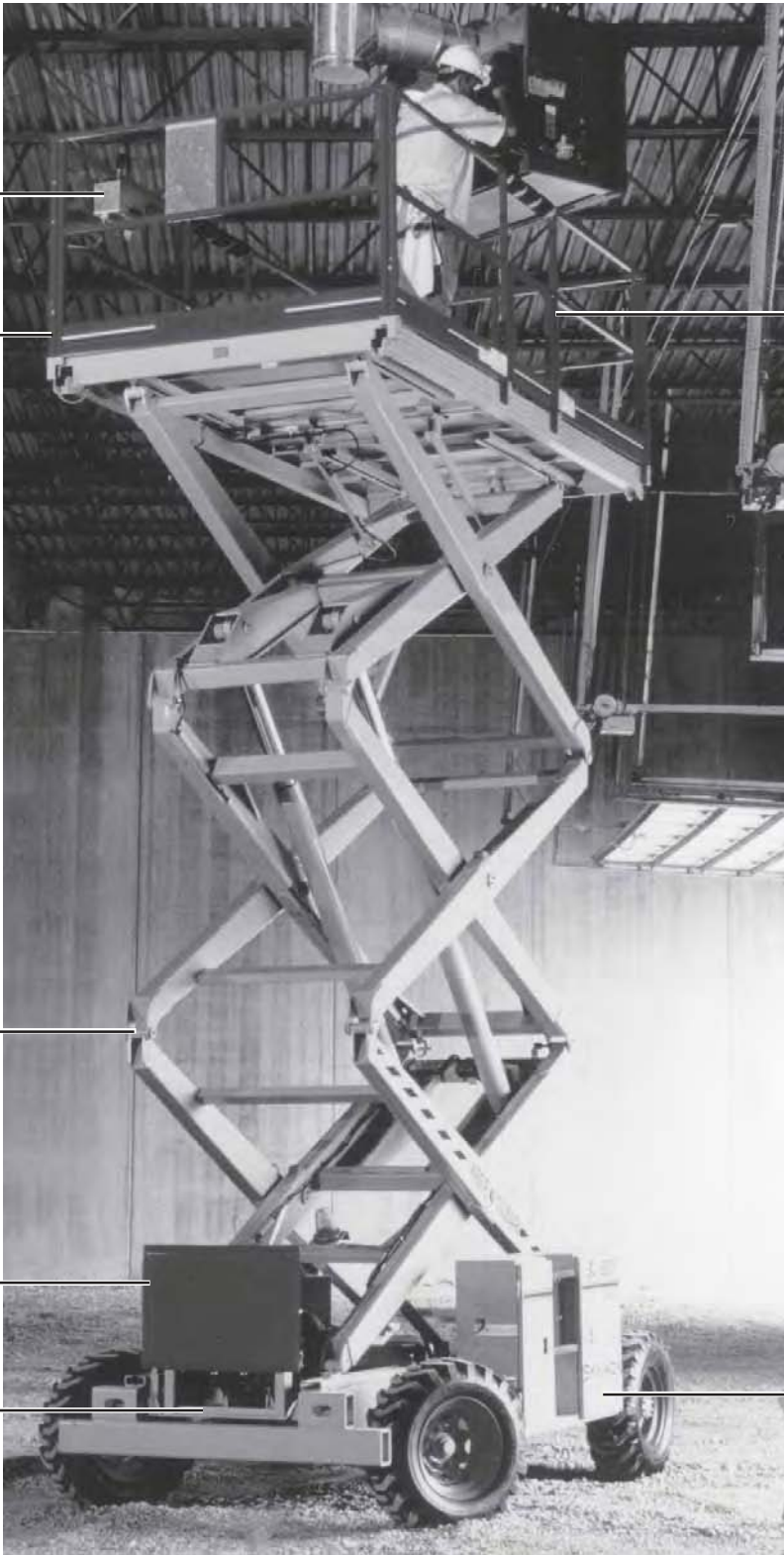

Figure 1-1. SKYJACK SJ-800 Series Work Platform

SECTION 2 OPERATION

Operating Controls Identification

The following descriptions are for identification, explanation and locating purposes only. A qualified operator **MUST** read and completely understand these descriptions before operating this work platform. Procedures for operating this work platform are detailed in the “**OPERATING PROCEDURES**” section. Both standard and optional controls are identified in this section. Therefore, some controls may be included that are not furnished on your work platform.

Base Controls

Electrical Panel

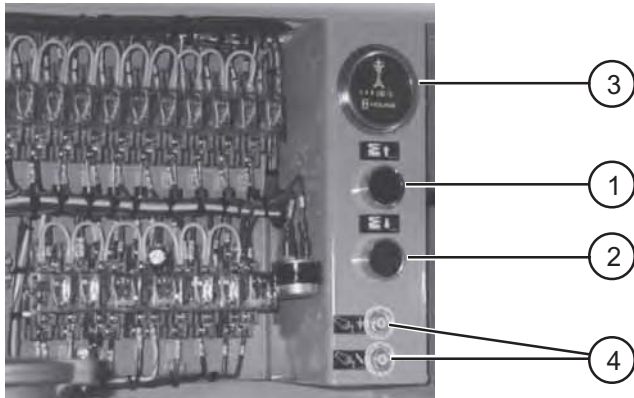

Figure 2-1. Electrical Panel

Electrical Panel - This control station is located in the Hydraulic/Electric Side Cabinet. It contains the following controls:

1. **Up Push-Button Switch** - This push-button switch will raise the platform to desired height.
2. **Down Push-Button Switch** - This push-button switch will lower the platform to desired height.
3. **Hour meter** - This gauge records engine running time.
4. **20 Amp Circuit Breaker Resets** - In the event of a power overload or positive circuit grounding, circuit breaker will pop out.

Emergency Battery Disconnect Switch

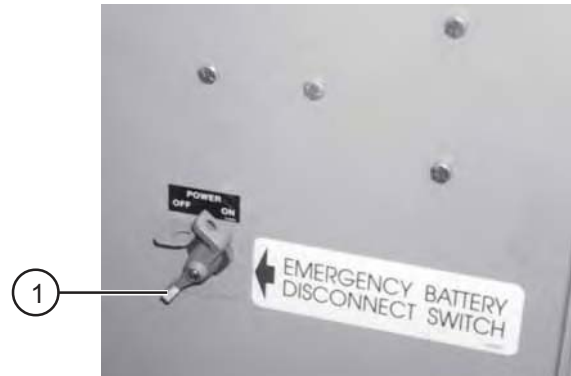

Figure 2-2. Emergency Battery Disconnect Switch

1. **Emergency Battery Disconnect Switch** Located at the front of the Hydraulic/Electric Side Cabinet, this switch when in the “OFF” position, disconnects power to all circuits. Switch **MUST** be in “ON” position to operate any circuit.

Engine Control Panel (Dual Fuel)

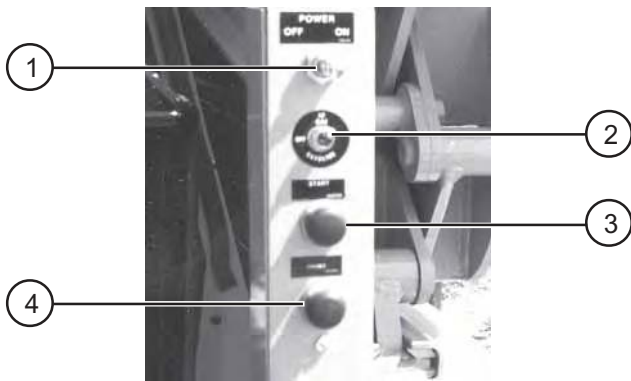

Figure 2-3A. Engine Control Panel -
Ford Gasoline Engine
(Shown with Dual Fuel)

Engine Control Panel - This control station is attached to the Engine Roll-out at the front of the base. It contains the following controls:

1. **Engine Off/On Switch** - This plunger-type switch, when pulled out, energizes the engine circuit and the operator's control box. To stop engine, push plunger in.
2. **Fuel Select Switch (Machines with Dual Fuel)** - Used to switch from LP GAS to gasoline
3. **Engine Start Push-Button** - This push-button switch energizes the engine starter motor.
4. **Engine Choke Push-Button** - This push-button switch sets the choke for starting a cold gasoline/propane engine.

Engine Control Panel (Diesel)

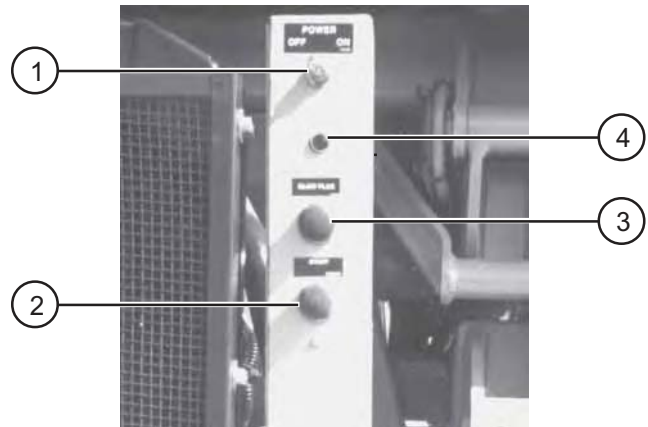

Figure 2-3B. Engine Control Panel -
Kubota Diesel Engine

Engine Control Panel - This control station is attached to the Engine Roll-out at the front of the base. It contains the following controls:

1. **Engine Off/On Switch** - This plunger-type switch, when pulled out, energizes the engine circuit and the operator's control box. To stop engine, push plunger in.
2. **Engine Start Push-Button** - This push-button switch energizes the engine starter motor.
3. **Engine Glow Plug Push-Button** - This push-button switch energizes the glow plug to aid in starting a cold diesel engine.
4. **Glow Plug Indicator Light** - This red lamp illuminates until the glow plugs have completed their timed heating cycle. When the lamp goes out, the engine is ready to be started.

Base Control Box/Station (CE)



Figure 2-4A. Base Control Box and Labels
(Located at rear of hydraulic/electric side cabinet)



Figure 2-4B. Base Control Station and Labels
(Located at rear of hydraulic/electric side cabinet)

Base Control Box/Station - This control station is found on the rear of the hydraulic/electric cabinet or on the rear of the base. It contains the following controls:

1. **Platform/Base Select Key Switch** - Key to "PLATFORM" position directs power to the operator's control box on the platform. Key to "BASE" position directs power to the base control box/station.
2. **Platform Up/Down Selector Switch** - This toggle switch raises or lowers the platform to a desired height.
3. **Emergency Stop Button** - This red "mushroom-head" shaped button switch is designed to disengage power to the platform controls.

Emergency Powered Extension Platform Retraction System (CE) (1000 Series only)

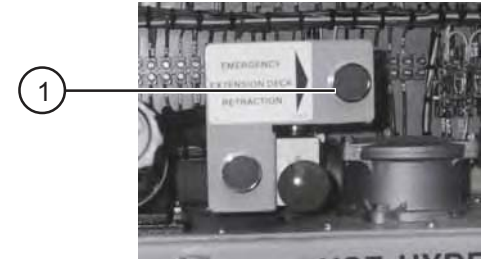

Figure 2-5. Powered Platform Emergency Retraction Push-Button

1. **Powered Platform Emergency Retraction Push-button** - This switch, when depressed, activates the platform retraction system on the platform in the event of an electrical system failure or an emergency.

1500W AC Inverter (Option)

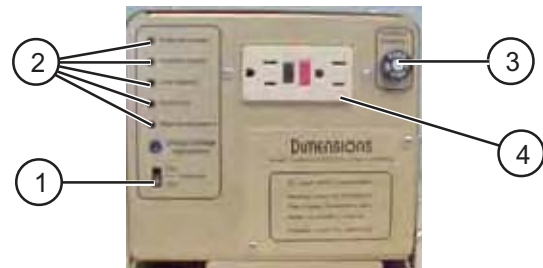

Figure 2-6. 1500W AC Inverter

Inverter - The inverter is located on the base of the machine, it has the following controls.

1. **ON/OFF Switch** - This slide switch will activate or terminates inverter function.
2. **Status LEDs** - These LEDs indicate the operating or fault status of the inverter .
3. **15 Amp Circuit Breaker** - In the event of a power overload or circuit grounding, this circuit breaker will pop out.
4. **GFCI Outlet** - During inverter operation, this outlet provides AC power.

Platform Controls Operator's Control Box

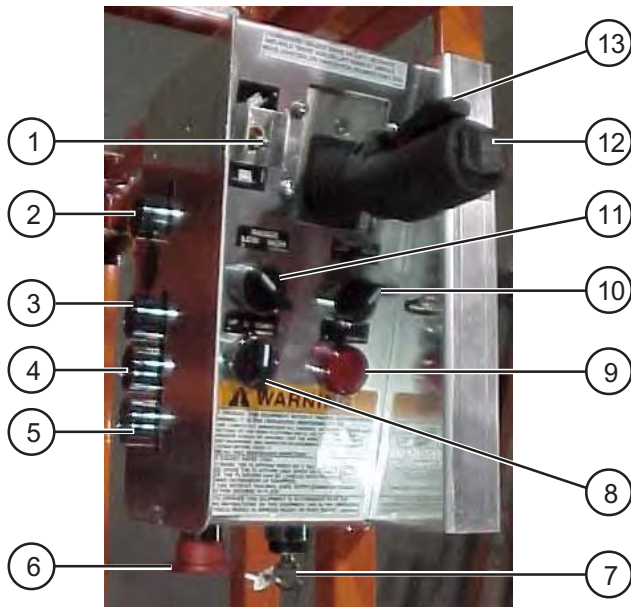



Figure 2-7. Operator's Control Box

Operator's Control Box - This metal control station is mounted at the right front of the platform. It contains the following controls:

1. Torque Toggle Switch - This toggle switch, when in the "  " position, cuts out High Range and 3rd speed to provide maximum torque when climbing grades and in rough terrain. When in the "  " position, all three speeds are available.

2. Operator Horn Push-Button - Located on the side of the Operator's Control Box, this push-button switch, when depressed, sounds an automotive-type horn.

3. Engine Choke Push-Button (Dual fuel engines) - Located on the side of the control box, this push-button sets choke for starting a cold gasoline engine.

Glow Plug Push-Button (Diesel Engines) - Located on the side of the control box, this push-button powers the glow plug for starting cold diesel engines.

4. Engine Start Push-Button - Located on the side of the control box, this push-button energizes the engine starter motor.

5. Enable Push-Button - When depressed and held, this push-button switch brings power to the lift or outrigger circuits.

6. Emergency Stop Button - When struck, this red push-button switch disconnects power to the control circuit.

7. Off/Lift/Drive Select Key Switch - Key to "OFF" position disconnects power to the control box. Key to "LIFT" position brings power to the Lift Enable Push-button. Key to "DRIVE" position brings power to the Drive/Steer Controller.

8. Up/Down Selector Switch - This rotating selector switch raises or lowers the platform to the desired height.

9. Platform Power Indicator Light - Light will glow when key switch is in "LIFT" or "DRIVE" position. Light will not glow when key switch is in "OFF" position.

10. Low/High Throttle Select Switch - This rotary switch allows selection between high and low engine throttle speeds.

11. Low/High Range Select Switch - This rotary switch selects "LOW" range (high torque) or "HIGH" range (high speed).

12. Drive/Steer Controller - A one-hand toggle type lever to control steer and three-speed drive motion. It is a "deadman" control which returns to neutral when released.

13. Drive Enable Switch - This momentary "Trigger" style switch energizes the drive/steer controller. It must be held depressed continuously while engaging either the drive or steer functions.

**Outrigger Controls (Option)
(Model 9250A, 7135 & 800 Series)**



Figure 2-8A. Outrigger Controls On Operator's Control Box



Figure 2-8B. Outrigger Controls On The Optional Control Box Console

Outrigger Controls - Located on the Operator's Control Box, these switches control each outrigger's extension and retraction

1. **Outrigger Up/Down Control Toggle Switches** - These switches control the extension and retraction of each individual outrigger

Hydraulic Generator Control (Option)

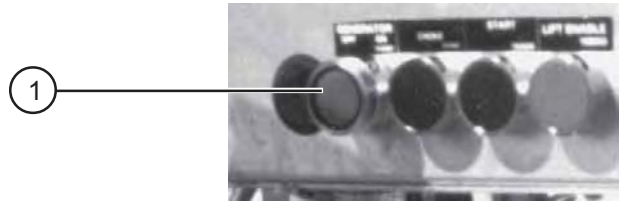

Figure 2-9A. Hydraulic Generator Control On The Main Control Box



Figure 2-9B. Hydraulic Generator Control On The Auxiliary Control Box

Hydraulic Generator Control - Located on the side of the Operator's Control Box or on the Auxiliary Control Box console. This push-button switch starts the hydraulic generator on the base.

1. **Hydraulic generator Off/On Push-Button Switch**
This illuminated push-button switch starts the base mounted generator. It illuminates when the generator is activated.
2. **Hydraulic generator Off/On Toggle Switch** This switch starts and stops the base mounted generator.

Powered Extension Platform Control Box (Option)

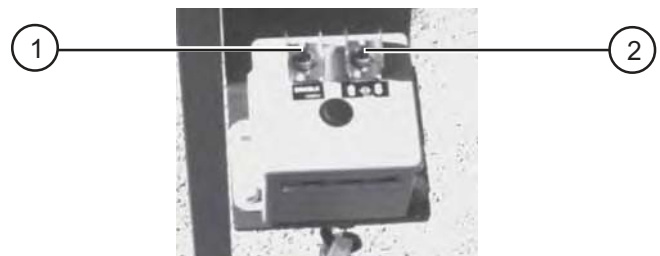

Figure 2-10. Powered Extension Platform Control Box

Powered Platform Control Box - This metal control station is mounted at the right front of the extension platform. It contains the following controls:

1. **Enable Switch** - This switch, when activated brings power to the Platform Extend/Retract Switch.
2. **Platform Extend/Retract Switch** - This switch, when activated extends/retracts the powered extension platform.

Identification And Operation of Safety Devices

Fold-Down Guardrail System

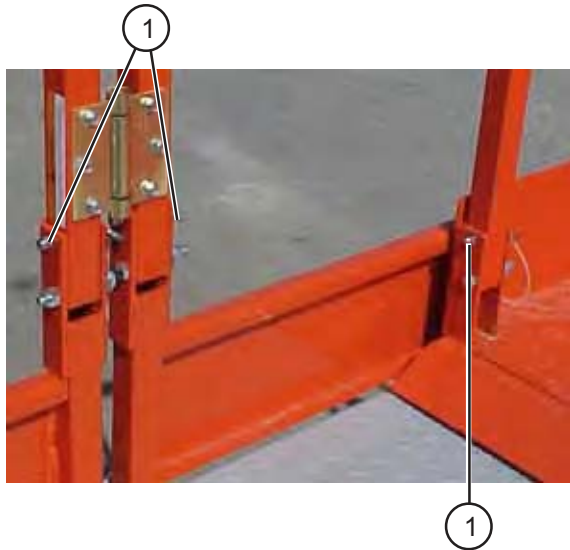

Figure 2-11. Fold-Down Guardrail System

Fold-Down Guardrail System - This system when folded down, reduces the shut height of the work platform for transporting and traveling through doorways.

1. **Guardrail Locking Pin W/Lanyard** - To fold the guardrail system down, remove the locking pin at each pivot point and lower each guardrail. To raise the guardrail system, swing up each guardrail and lock in place with the locking pins ensuring that the detent ball of each pin is clear of the side of the pivot brackets. (Figure 2-12.)

Warning

The guardrail system **MUST** be upright and locked in place before resuming normal operation. Check the guardrail system for loose or missing locking pins before operating this equipment!

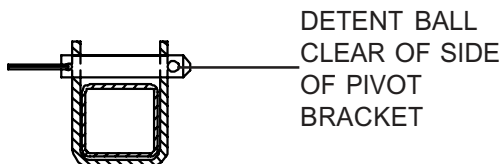

Figure 2-12. Correct Position of Locking Pin

Base Controls - Manual Safety Bar



Figure 2-13. Safety Bar

1. **Safety Bar** - Designed to support the scissors assembly (when properly positioned), the safety bar **MUST** be used for inspection and performing maintenance or repairs within the scissors assembly. To lower safety bar, push lock lever rearward and the safety bar will drop. Follow procedure on safety bar decal to properly position safety bar.

Warning **Crushing Hazard**

DO NOT reach through scissor assembly without the safety bar properly positioned. Failure to avoid this hazard will result in death or serious injury!

Operating Procedures

The following descriptions are for Operating Procedures. A qualified operator **MUST** read and completely understand these descriptions before operating this work platform.

Set-Up Procedure

1. Remove all packing materials and inspect for damage incurred during transport. This is normally required for equipment being put into service for the first time, after the equipment has been unloaded.

Note

Report any damage to delivery carrier immediately.

2. Inspect work platform thoroughly and remove any foreign objects.
3. Raise the side, extension platform (if so equipped), and gate railings to their upright position and lock in place with locking pins. Lock side railings to front railings with locking pins.
4. Remove the operator's control box from its shipping container and secure it to the railing at the right front of the platform. Attach the control cable and power deck extension cable (if so equipped) to the scissor's control cable.
5. Open the fuel tank side cabinet door. Fill the fuel tank to "F" level on fuel gauge with the proper fuel. (Refer to decal on fuel tank)
6. Close the fuel tank side cabinet door.
7. Machines with Dual Fuel:
Make sure propane hose coupler is properly secured at propane cylinder and valve on propane cylinder is opened all the way.
8. Open the hydraulic tank side cabinet door. Check the hydraulic oil level (scissors must be fully lowered) in the tank. Level should be at or slightly above the top mark on the sight glass. If required, add a quality grade hydraulic oil such as ATF Dexron III (ESSO).
9. Check the battery fluid level. If fluid level is not at FULL mark on battery, add distilled or demineralized water only.



Warning Explosion Hazard

Keep flames and sparks away. **DO NOT** smoke near batteries.

First Aid

Immediately flush eyes with cold water if electrolytic acid is splattered into them. Seek medical attention.

10. Move the work platform to a level, firm test area where the work platform can be vertically extended to its maximum working height. If the work platform is to be pushed, towed or winched, ensure that the parking brake has been disengaged. When pushing, towing or winching, **DO NOT** exceed 2 mph (3.2 kph).

Using the Base Controls:

11. Turn the Emergency Power Disconnect Switch to "ON" position.

Using the Platform Controls:

12. Pull out the Emergency Stop Button.

Note

Engine will not start unless this button is in the "ON" position.

13. Insert key into Off/Lift/Drive Select Key Switch and turn to "LIFT" position.

Note

Start engine in low throttle position.

Using the Engine Controls on the Engine:

14. Pull Engine Off/On Switch plunger out.
15. Select desired fuel source with Fuel Select Switch. (Gasoline engines with dual fuel)

Note

Refer to label on inside of engine front guard for fuel switch sequence.

16. Depress and hold the Choke Push-Button. (Gasoline engines) Depress and hold Glow Plug Push-Button for 15 to 20 seconds. (Diesel engines)

17. Depress and hold the Engine Start Push-Button until the engine starts, then release. **DO NOT** over crank the starter. Release the Engine Choke Push-button.

Using the Base Controls:

18. Raise the platform with the “Up” Selector Switch on the Base Control Box until the open height between scissors center pins is approximately 21” (53.34cm) for 800 & 1000 Series and 18” (45.72cm) for 600 Series.
19. Unlatch and carefully swing down the safety bar. Follow procedure on safety bar decal to properly position safety bar.



Warning
Crushing Hazard

DO NOT reach through scissor assembly without the safety bar properly positioned. Failure to avoid this hazard will result in death or serious injury!

20. Slowly lower the platform with “Down” Selector Switch on the Base Control Box until the scissors assembly is firmly resting on the safety bar.
21. Inspect all hoses, fittings, wires, valves, etc. for leaks, loose or missing parts, hidden damage, and foreign material.
22. Raise the platform with the Up Switch until the open height between scissors center pins is approximately 21” (53.34cm) for 800 & 1000 Series and 18” (45.72cm) for 600 Series.
23. Carefully swing up safety bar and lock in position.
24. Again, raise the platform with the Up Switch until the platform has reached maximum working height.

Note

Refer to Table 1-1. Specifications and Features for proper lift and lowering times.

25. Use the Down Switch to lower the platform to it's fully lowered position.
26. Your SKYJACK Model is now ready for use by an authorized, qualified operator who has read and completely understands ALL of Section 2, OPERATION in this manual.

Operating Procedures

Prestart Checks

1. Carefully read and completely understand ALL of Section 2, OPERATION in this manual and ALL warnings and instruction decals on the work platform.
2. Check for any obstacles around the work platform and in the path of travel such as holes, drop offs, debris, ditches and soft fill.
3. Check overhead clearances.
4. Make sure all guardrails are in place and locked in position.

OPERATOR'S CHECKLIST

INSPECT AND/OR TEST THE FOLLOWING DAILY OR AT BEGINNING OF EACH SHIFT

1. OPERATING AND EMERGENCY CONTROLS.
2. SAFETY DEVICES AND LIMIT SWITCHES.
3. PERSONAL PROTECTIVE DEVICES.
4. TIRES AND WHEELS.
5. OUTRIGGERS (IF EQUIPPED) AND OTHER STRUCTURES.
6. AIR, HYDRAULIC AND FUEL SYSTEM(S) FOR LEAKS.
7. LOOSE OR MISSING PARTS.
8. CABLES AND WIRING HARNESSSES.
9. PLACARDS, WARNINGS, CONTROL MARKINGS AND OPERATING MANUALS.
10. GUARDRAIL SYSTEM, INCLUDING LOCKING PINS.
11. ENGINE OIL LEVEL (IF SO EQUIPPED).
12. BATTERY FLUID LEVEL.
13. HYDRAULIC RESERVOIR LEVEL.
14. COOLANT LEVEL (IF SO EQUIPPED).
15. PARKING BRAKE (CHECK OPERATION).



Warning

DO NOT OPERATE THIS EQUIPMENT WITHOUT PROPER AUTHORIZATION AND TRAINING. DEATH OR SERIOUS INJURY COULD RESULT FROM IMPROPER USE OF THIS EQUIPMENT!

Operator Qualifications

Only trained and authorized persons should use this work platform. Safe use of this work platform requires the operator to understand the limitations and warnings, operating procedures and operator's responsibility for maintenance. Accordingly, the operator **MUST** understand and be familiar with this operating manual, its warnings and instructions and **ALL** warnings and instructions on the work platform. The operator also **MUST** be familiar with employer's work rules, related government regulations and be able to demonstrate his/her ability to understand and operate **THIS** make and model work platform in the presence of a qualified person.

Start and Operation

Using the Base Controls:

1. Turn Emergency Power Disconnect Switch to "ON" position. CE units - make sure base control emergency stop button is in the "ON" position.

Using the Engine Controls on the Engine:

2. Pull Engine Off/On Switch plunger out.
3. Select desired fuel source with Fuel Select Switch. (Gasoline engines with Dual Fuel)

Note

Refer to label on inside of engine front guard for fuel switch sequence.

4. Use the ladder of the work platform to access the work platform deck. Close and latch the gate.

Using the Platform Controls:



Warning

TO PROTECT AGAINST UNINTENDED MOVEMENT OF THE WORK PLATFORM, PUSH IN THE EMERGENCY STOP BUTTON AFTER YOU HAVE ARRIVED AT YOUR DESIRED LOCATION OR ELEVATION.

5. Pull out the Emergency Stop Button.



6. Insert key into the Off/Lift/Drive Select Key Switch, then select "LIFT" or "DRIVE". Select "LOW" position with HI/LOW Throttle Select Switch.
7. If the engine is cold, depress and hold the Engine Choke Push-button (Gasoline engines) or depress and hold the Glow Plug Push-button for 15 to 20 seconds (Diesel engines) and release.
8. Depress and hold the Engine Start Push-Button until engine starts, then release. **DO NOT** over crank the starter.
9. Select "HIGH" position with the Low/High Throttle Select Switch.
10. **To Raise the Platform:** Ensure the emergency stop button is pulled out. Select "LIFT" position with Off/Lift/Drive Select Key Switch. Depress and hold the Enable Push-button, then select "↑" (up) position with Up/Down Selector Switch. Release switch to stop.
11. **To Lower the Platform:** Ensure the emergency stop button is pulled out. Select "LIFT" position with Off/Lift/Drive Select Key Switch. Depress and hold the Enable Push-button, then select "↓" (down) position with Up/Down Selector Switch. Release switch to stop. A warning alarm will sound while lowering.
12. **If High Torque is Desired:** Select "LOW" position with the Low/High Range Select Switch. Select "LOW" range when climbing grades, traveling in rough terrain and when loading or unloading the work platform.
If High Speed is Desired: Select "HIGH" position with the Low/High Range Select Switch. Select "HIGH" range when traveling on a hard level surface with the platform fully lowered.
13. **To Drive Forward or in Reverse:**
 - 1- Ensure the emergency stop button is pulled out. Select "DRIVE" position with the Lift/Off/Drive Key Switch.
 - 2- Activate and hold the Drive Enable trigger switch (by squeezing it towards the joystick).
 - 3- Push or pull the controller handle forward or backward to the desired speed and direction of platform travel.
 - 4- Return the joystick to the neutral center position to stop. Release the Enable trigger switch.

14. **To Steer:** Select “DRIVE” position with Off/Lift/Drive Select Key Switch. Activate and hold the Drive Enable trigger switch (by squeezing it towards the joystick), then press the rocker switch on top of the Drive/Steer Controller handle in the direction you wish to steer.
15. **To Climb a Grade:** Select “” position with the Torque Toggle Switch.



Warning

MACHINE MUST BE IN FULLY RETRACTED POSITION

16. **To extend/retract a manual extension platform:** To extend the platform remove the retaining locking pins and push/pull the extension platform using the push bar until the desired extension is reached. Reinsert the locking pins to prevent accidental movement of the extension deck during travel or transport.
17. **To extend/retract a hydraulic powered extension platform:** To extend the platform, turn key to “LIFT” position with Off/Lift/Drive Select Key Switch, activate the Enable Switch, then push the extension/retraction toggle switch to the “” position until desired extension is reached. Release switch to stop. To retract the platform, turn key to “LIFT” position with Off/Lift/Drive Select Key Switch, activate the Enable Switch, then push the extension/retraction toggle switch to the “” (retract) position until desired retraction is reached. Release switch to stop.
18. **To switch from LP GAS to gasoline:** Move fuel selector switch on engine control panel to the “GASOLINE” position. To shut off fuel, move switch to “OFF” position.
To switch from gasoline to LP GAS: With the engine running, move switch to “OFF” position and let engine run until gasoline is exhausted from carburetor. When engine stops, move switch to “LP GAS” position and restart engine. Make sure LP GAS valve is ON when switching from gasoline to LP GAS and valve is OFF when switching from LP GAS to gasoline.

Shutdown Procedure

1. Completely lower the platform.
2. Turn key to “OFF” position and remove key from Off/Lift/Drive Select Key Switch in control box.
3. Push Emergency Stop Button(s) in.
4. Turn Emergency Power Disconnect Switch to “OFF” position. CE units - remove key then push in Emergency Stop Button on the base control box.

Emergency Lowering System (600 & 800 Series)

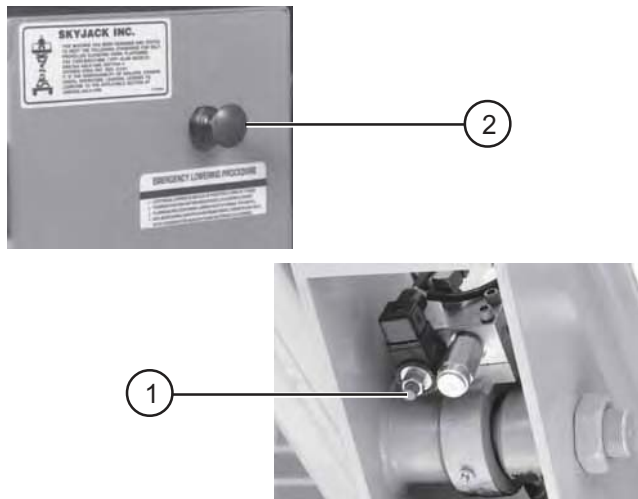

Figure 2-14. Emergency Lowering System

Emergency Lowering System - This system allows platform lowering in the event of an emergency or an electrical system failure.

1. **Holding Valve Manual Override Knob** - Located on the holding valve at the bottom of each lift cylinder, these red knurled knobs when depressed and turned counter-clockwise allow hydraulic oil to bypass each holding valve. The red knurled knobs on each holding valve **MUST** be depressed and turned clockwise to restore normal operation. An access rod for reaching the elevated manual override knob shall be provided for CE units only.

2. **Emergency Lowering Valve** - Pull out and hold the Emergency Lowering Valve plunger, and the platform will gradually lower. Located at the rear of the hydraulic/electric side cabinet, this pull-type valve when used in conjunction with the holding valve manual overrides, allows platform lowering in the event of an emergency or electrical system failure. Activate all holding valve manual override knobs, then pull and hold the plunger out to lower platform. Release to stop.

 **Warning**
Crushing Hazard

Keep clear of scissors mechanism when using emergency lowering valve! After emergency lowering is completed, the red knurled knobs on each holding valve **MUST** be depressed and turned clockwise to restore normal operation.

Emergency Lowering System (1000 Series only)

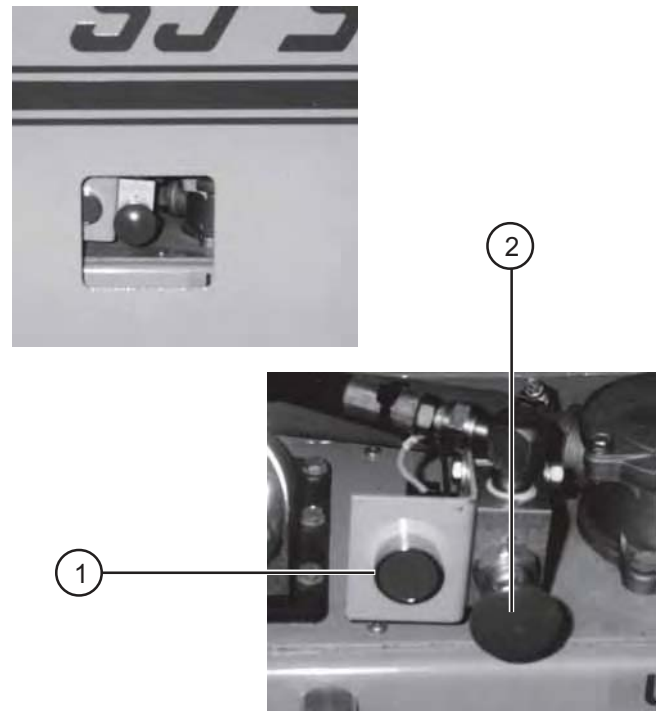

Figure 2-15. Emergency Lowering System

Emergency Lowering System - Located on the hydraulic tank and accessed through a hole in the hydraulic/electric cabinet door, this system allows platform lowering in the event of an emergency or an electrical system failure. An auxiliary battery provides power for the push-button switch to activate a lowering valve on the base of each lift cylinder.

Emergency Lowering Push-Button Switch (1) and Emergency Lowering Valve (2) - To lower the platform, depress and hold this red push-button switch, then pull the valve plunger out. The platform will gradually lower. Release the valve plunger to stop.

Outrigger Operating Procedures

A. Before Operation

1. Check overhead clearances and ground obstructions. This will require the operator to move around the platform.
2. Check that the platform is fully lowered. (The outrigger controls are cut out when the platform is raised.)
3. Check that the supporting surfaces under the tires and outrigger pads is firm and capable of supporting machine and related load. **DO NOT** place outrigger pad on a street drain, manhole cover or other supported surfaces.

B. Operation - Extending The Outriggers

1. Rotate Key Switch to "LIFT" position.
2. Depress and hold the Enable Push-button, then push and hold each Outrigger Up/Down Toggle Switch to "DOWN" position extending each of the outriggers to obtain firm ground contact.
3. **Check outrigger pad contact surface!** Make adjustments as necessary.
4. Again, depress and hold the Enable Push-button, then push and hold each Outrigger Up/Down Toggle Switch to "DOWN" position extending each of the outriggers until the machine is completely supported by the outriggers.
5. Level the machine. **AGAIN, CHECK THE OUTRIGGER PAD CONTACT SURFACE!**
6. To raise the platform, press and hold the Enable Push-Button, then rotate the Up/Down Selector Switch to the "↑" position.

C. Operation - Retracting The Outriggers

1. Fully lower the platform.
2. Depress and hold the Enable Push-button, then push and hold pairs (front or rear) of Outrigger Up/Down Toggle Switches to "UP" position until the outriggers are fully retracted.

Note

Cut out switches are used to protect the outriggers from being damaged. If machine will not drive, visually check to see that **ALL** outriggers are fully retracted.

D. During Operation

1. If alarm sounds during operation, the platform is not level. **LOWER THE PLATFORM IMMEDIATELY!** Make the necessary adjustments to level the machine!

Hydraulic Generator (Option)

For models with generator controls on the main control box:

1. To start the hydraulic generator, Ensure the engine is on high throttle by selecting "HIGH" on the "Low/High Throttle Select" switch. Select the "LIFT" position with the "Off/Lift/Drive" key switch, then depress hydraulic generator push-button on the side of the operator's control box. The push-button will illuminate and generator on base will start. To restore normal operation, depress push-button again. The light in push-button will go out and the generator will turn off.

Note

While hydraulic generator push-button switch light is illuminated, the lift and drive circuits in the Operator's Control Box are cut out.

For models with generator controls on the auxiliary or optional control box:

1. To start the hydraulic generator, select the "LIFT" position with the "Off/Lift/Drive" key switch. With the engine running, flip the hydraulic generator toggle on the auxiliary control box to the energized position. The engine will automatically switch to high throttle and the generator on the base will start. To restore normal operation, flip the toggle switch to the "OFF" position. The generator will turn off.

Note

Activating any lift or outrigger functions will disable the generator. Changing the keyswitch setting, activating the emergency stop or an engine stall will also result in stopping generator function. The platform may be lowered during generator operation.

Electrical Inverter (Option)

1. Turn the main disconnect switch to the "ON" Position.
2. Turn the "ON/OFF" switch located on the front face of the inverter to the "ON" Position.

3. Start the machine and turn the throttle switch to the high idle setting.
4. Inverter activation is indicated by a glowing green LED on the front face of the inverter.
5. To turn off the inverter, shut down the platform engine and/or slide the "ON/OFF" switch on the inverter to the "OFF" position.

Note

The inverter will only supply power to the platform when the engine is running and the throttle switch is set to the HIGH idle position. Deselecting the high idle throttle setting or stopping the engine will turn the inverter off.

Winching and Towing Procedures (600 & 800 Series)

Warning

When Towing, **DO NOT** drive onto a downward slope or brake the towing vehicle rapidly.

Preparation for Winching Or Towing

Parking Brake System



Figure 2-16. Disc Parking Brake

1 - 3. Parking Brake Disc -This device disengages the brake disc(1) when driving forward or in reverse. A hydraulic brake cylinder(2), linked to a disc caliper(3), engages and disengages a brake disc on the rear axle drive shaft yoke. The brake **MUST** be manually disengaged for pushing, towing or winching. **DO NOT** push or tow the work platform onto a downward slope or pull the platform down an incline towards the winch. The special procedure for manually disengaging the parking brake is as follows:

Warning

DO NOT manually disengage the parking brakes if the work platform is on a slope.

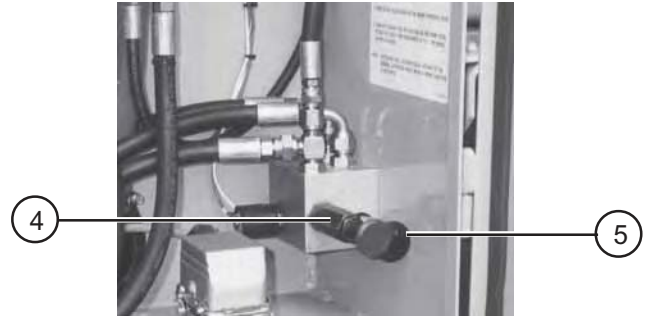

Figure 2-17. Parking Brake Release Hand Pump and Brake Valve Plunger

4 - 5. Parking Brake Release Hand Pump(4) and Brake Valve Plunger(5) - Located on the brake manifold in the hydraulic electric side cabinet, this hand operated pump **MUST** be used when pushing, towing or winching the work platform. To release the parking brake:

1. Make sure that the work platform is on level ground. Chock or block the wheels to keep work platform from rolling.
2. Turn Emergency Power Disconnect Switch to "OFF" position.
3. Depress the black plunger on the Brake Valve until the plunger stays in.
4. Grasp the red hand pump plunger and rapidly depress 60 to 80 times until firm resistance is felt. The brake is now released.
5. Remove the wheel chocks or blocks, then push, tow or winch the work platform to the desired location. When pushing, towing or winching, **DO NOT** exceed 2 mph (3.2 km/h). **DO NOT** push or tow the platform onto a downward slope or pull the platform down an incline towards the winch.
6. Position machine on a firm and level surface. Chock or block the wheels to prevent the platform from rolling or re-engage the parking brake by momentarily activating the drive function.

Note

The parking brake will reset automatically when the work platform is put back into service.

Winching And Towing Procedures (1000 Series only)

Warning

When Towing, **DO NOT** drive onto a downward slope or brake the towing vehicle rapidly.

Parking Brake System

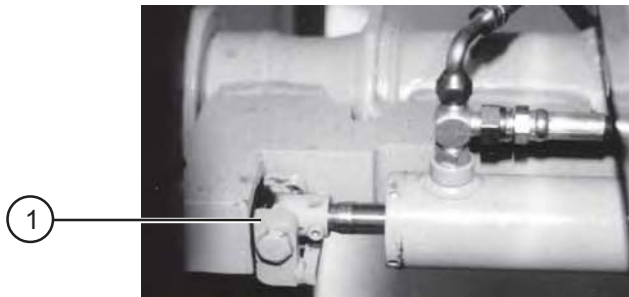

Figure 2-18. Parking Brake

1. **Parking Brake** - This spring applied, hydraulically released parking brake is essentially automatic. Pins retracted and extended by single-acting hydraulic cylinders engage brake discs on the rear wheels when lifting, lowering, parking and steering. The pins disengage when driving. The brake pins **MUST** be manually disengaged for pushing, towing or winching. **DO NOT** push or tow the work platform onto a downward slope or pull the platform down an incline towards the winch. The special procedure for manually disengaging the parking brakes is as follows:

Warning

DO NOT manually disengage the parking brakes if the work platform is on a slope.

Preparation for Winching Or Towing

1. Turn Emergency Power Disconnect Switch to “OFF” position. Make sure that the work platform is on level ground.
2. Chock or block the wheels to prevent the platform from rolling.
3. **For Left-Hand Brake:** Using a 3/4" wrench, rotate the block on the brake pin 90° clockwise. The brake pin should be clear of the brake disc. **For Right-Hand Brake:** Using a 3/4" wrench, rotate the block on the brake pin 90° counterclockwise. The brake pin should be clear of the brake disc.
4. Remove the wheel chocks or blocks, then push, tow or winch the work platform to the desired location. When pushing, towing or winching, **DO NOT** exceed 2 mph (3.2 km/h). **DO NOT** push or tow the platform onto a downward slope or pull the platform down an incline towards the winch.
5. Position machine on a firm level surface. Chock or block the wheels to prevent the platform from rolling and re-engage the parking brake by momentarily activating the drive function.

Note

The parking brakes will reset automatically when the work platform is put back into service.

Table 2-1. Owner's Annual Inspection Record

MODEL NUMBER _____		SERIAL NUMBER _____						
RECORDING DATE								
RECORDING YEAR #	1	2	3	4	5	6	7	8
OWNER'S NAME								
INSPECTED BY								

Table 2-2. Tire Specifications



Air pressure can affect stability. Temperature changes can affect air pressure. It is important to visually inspect all tires for proper tire inflation prior to use. Tires should be checked in the operating conditions experienced by end user on a daily basis. Tire inflation pressures must be checked weekly with a calibrated gauge. If the measured pressure is less than the specification, re-inflate to the pressure specified. Tires shall also not be subject to over-inflation above the recommended specification and tolerance range.

Tire		Fill Specification			Usage [†]										
Size	Fill Type	Ply Rating	Pressure Psi (kPa)		600 Series				800 Series			1000 Series			
			Factory	Listed Sidewall Maximum	7027	7027F	71XX	71XXF	8831	8831F	8841	8841F	9250	9250F	9250A
#6 30-10-16.5 NHS	Air	8	50* (344.7)*	65 (448.2)	S		S♦		S				S		
#6 32.3-10-16.5 OTR HD Stabilizer		10	70* (482.6)*	75 (517.1)						S					
#6 30-10-16.5 OTR Outrigger		10	75* (517.1)*	75 (517.1)			S								
#7 31-15.5-15 NHS		8	45* (310.3)*	Not Available	O		O		O		O		O		
#6F 30-10-16.5 NHS	Solid Urethane	8	**			S		S††		S		S		S	S
#7F 31-15.5-15 NHS		8	**			O		O		O		O		O	

- * Factory preset @ 20°C, Check pressures regularly as tires can lose pressure over time and over different ambient temperatures even under normal conditions.
- ** Urethane used for filling #6F and #7F tires MUST be 55 durometer.
- † Usage: (S)tandard Or (O)ptional
- †† #6 foam tire is 30-10-16.5 OTR Outrigger
- ♦ Standard tires on early 7127 models only.

Rim Backspace Diagram

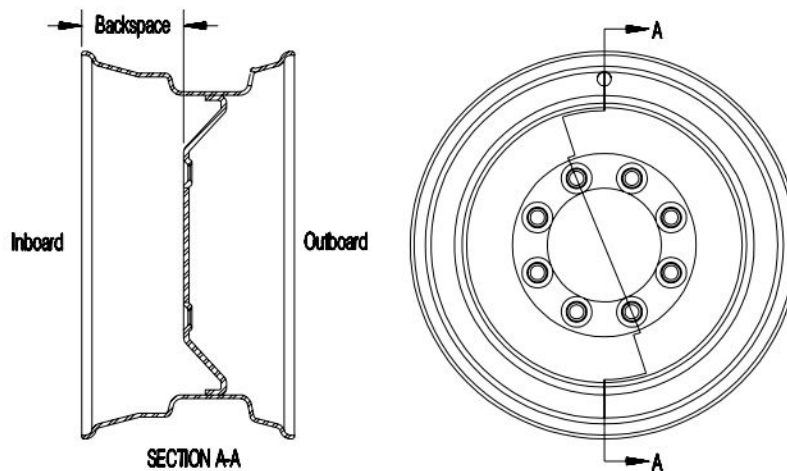

Rim Size	Backspace inches(mm)							
	7027	7127 (Earlier models)	7127 (Later models)	7135	8831	8841	9250	9250A
#6 & #6F	4-3/4" (121)	4-3/4" (121)	3-3/4" (95)	3-3/4" (95)	4-3/4" (121)	4-3/4" (121)	3-3/4" (95)	3-3/4" (95)
#7 & #7F	All models are 5-5/16" (135)							

Table 2-3. Maximum Platform Capacities (Evenly Distributed)

MODEL		Main Platform		First Extension		Second Extension		Total Platform Capacity
		Capacity	Number Of Occupants	Capacity	Number Of Occupants	Capacity	Number Of Occupants	
7027 & 7127	No extension Platform	1500 lbs. (680 kg)	5	-	-	Not Available		1500 lbs. (680 kg)
	One Extension Platform	1000 lbs. (454 kg)	3	500 lbs. (227 kg)	2			1500 lbs. (680 kg)
7135	One Extension Platform	650 lbs. (295 kg)	3	350 lbs. (159 kg)	1			1000 lbs. (454 kg)
8831	No extension Platform	2500 lbs. (1134 kg)	6	-	-	-	-	2500 lbs. (1134 kg)
	One Extension Platform	1500 lbs. (680 kg)	4	500 lbs. (227 kg)	2	-	-	2000 lbs. (907 kg)
	Two Extension Platforms	500 lbs. (227 kg)	2	500 lbs. (227 kg)	2	500 lbs. (227 kg)	2	1500 lbs. (680 kg)
8831F	No extension Platform	2500 lbs. (1134 kg)	6	-	-	-	-	2500 lbs. (1134 kg)
	One Extension Platform	1500 lbs. (680 kg)	4	500 lbs. (227 kg)	2	-	-	2000 lbs. (907 kg)
	Two Extension Platforms	800 lbs. (363 kg)	2	500 lbs. (227 kg)	2	500 lbs. (227 kg)	2	1800 lbs. (817 kg)
8841	No extension Platform	1500 lbs. (680 kg)	5	-	-	-	-	1500 lbs. (680 kg)
	One Extension Platform	1000 lbs. (454 kg)	2	500 lbs. (227 kg)	2	-	-	1500 lbs. (680 kg)
	Two Extension Platforms	500 lbs. (227 kg)	***	500 lbs. (227 kg)	***	500 lbs. (227 kg)	***	1500 lbs. (680 kg)
8841F	No extension Platform	2000 lbs. (907 kg)	6	-	-	-	-	2000 lbs. (907 kg)
	One Extension Platform	1000 lbs.** (454 kg)	3	500 lbs. (227 kg)	2	-	-	1500 lbs.** (680 kg)
	Two Extension Platforms	500 lbs.** (227 kg)	***	500 lbs. (227 kg)	***	500 lbs. (227 kg)	***	1500 lbs.** (680 kg)
9250	No extension Platform	2000 lbs. (907 kg)	6	-	-	-	-	2000 lbs. (907 kg)
	One Extension Platform	1000 lbs. (454 kg)	4	500 lbs. (227 kg)	2	-	-	1500 lbs. (680 kg)
	Two Extension Platforms	500 lbs. (227 kg)	2	500 lbs. (227 kg)	2	500 lbs. (227 kg)	2	1500 lbs. (680 kg)
9250A	No extension Platform	1350 lbs. (612 kg)	5	-	-	-	-	1350 lbs. (612 kg)
	One Extension Platform	850 lbs. (386 kg)	3	500 lbs. (227 kg)	2	-	-	1350 lbs. (612 kg)

NOTE: Occupants AND materials are not to exceed rated load.
 Capacities listed are for standard machines equipped with #6 tires except for model 9250A which is equipped with #6 foam filled tires.
 Refer to capacity label at sides of platform for additional information and for models equipped with options.
 ** Capacity is increased by 200 lbs. (91 kg) for European and CSA applications.
 *** Occupant capacity is a maximum of 4 Persons with no more than 2 people on an extension.

Table 2-4. Maintenance And Inspection Schedule

	Daily	Weekly	Monthly	3 Months	6 Months	12 Months*
Engine						
Fuel leaks	A					A
Engine oils	H & I					H & I
Engine RPM			G			G
Fuel filter					F	F
Belts/Hoses			A & C			A & C
Muffler				B, C & J		B, C & J
Air cleaner			A		I	A & I
Fuel tank cap	B & C					B & C
Coolant level	A & L					A & L
Mechanical						
Structural damage/welds	A					A
Locking Pins/Retainers	A & B			C		A, B & C
Parking brake	B					B
Tires/wheels & fasteners	A, B, C & R	O & S				A, B, C & O
Guides/ rollers & slider pads	A, B & N					A, B & N
Railings/Entry chains/gates	A, B & C					A, B & C
Bolts and fasteners	A	C				A & C
Safety Bar		B				B
Gear Oil**			A & H			A, H & F
Rust			A			A
Wheel Bearings & King pins	A			B & E		A, B & E
Steering cylinder & tie rod	A			B & E		A, B & E
Electrical						
Battery fluid level	A					A
Control switches/Indicator Lights	A & B					A & B
Cords & wiring	A					A
Battery terminals			A & C			A & C
Generator/receptacle	A	B				A & B
Terminals & plugs			C			C
Limit Switches	B					B
Tilt Switch	A & B	B				A & B
Hydraulic						
Hydraulic oil	H					H & Q
Hydraulic hoses/fittings	A & P		C			A, C & P
Lift/lowering speeds		G				G
Cylinders		A & B				A & B
Emergency lowering		B				B
Lift capacity			D			D
Hydraulic oil & oil filter			F			F
Miscellaneous						
Labels and manual	A, K & M					A, K & M
Lanyard Attachments	A & C					A & C
Notes						
A. Visually Inspect. B. Check operation. C. Check tightness. D. Check relief valve setting. Refer to serial number nameplate E. Lubricate. F. Replace. G. Refer to Table 1-1 specifications and features. H. Check oil level. I. Refer to engine manual. J. Check noise level. K. Replace if missing or illegible. L. Check only when cooled.			M. Proper manual must be in box N. Ensure there is no metal to metal contact with slider, slider side or running surface. Check for free movement of surface. Also check for free movement of the slider pin through the slider and pad. O. Ensure proper torquing procedure and sequence is followed. P. Check for leaks. Q. Have oil sample tested. R. Visually inspect for proper inflation. S. Check pressure with a calibrated gauge. (Refer To Table 2-2.) * Record inspection date and signature ** Gear Oil Requirements: Axle: ESSO GX 85W-140 Center Drive: ESSO GX 85W-140			



MOBILE ELEVATING PLATFORMS

www.skyjackinc.com